



Cryogen: Coolant at the right spot.

COOL

sCO₂ cools the cutting edge in a safe and clean way, thanks to powRgrip® with an optimum dosage.

CLEAN

No contamination at all, therefore no necessity of additional cleaning of the workpiece afterwards.

CRYO-powRgrip®

PG-CRYO collets offer the latest tool cooling technology, for a clean chipping of workpieces (i.e. Medical industries).

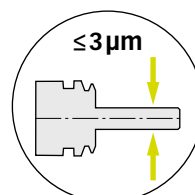

Total system runout
TIR ≤ 3 μm at 3 x D.

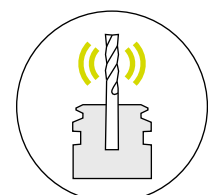

Excellent vibration dampening.

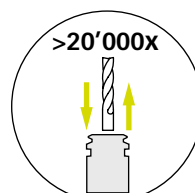

Maximum clamping force and low runout, even after 20'000 tool changes.

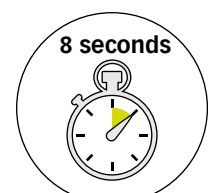

Tool ready for use in 8 seconds with PGU 9500.

The major difference of tool holding systems

Solution: Reducing of the condensation space

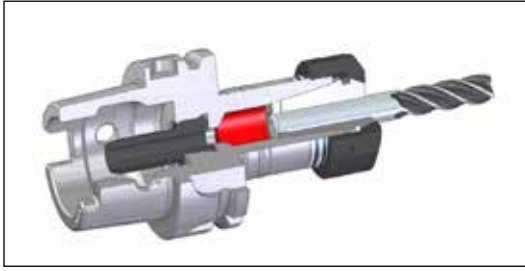

Competitor solution

Typical tool clamping system, with the risk of icing of the holder, due to the gaseous state behaviour of scCO_2 between coolant pipe and tool.

PG-CRYO – Toolholder

The cooling medium will be directly led to the cutting edge through the cutting tool. The scCO_2 expands at the cutting edge and the ice snow provides an efficient and clean chipping.

State of aggregation diagram

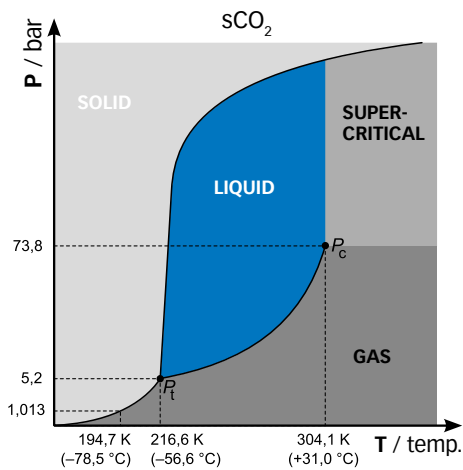

Benefit of CRYO-powRgrip®

- Perfect guidance of the cooling medium to the cutting edge
- Tool life increase
- Productivity increase, due to higher cutting parameters
- Better surface finishing
- No disposal of the cooling fluid necessary
- No necessity of workpiece cleaning
- 100% recycling of the chips
- Quick tool change with powRgrip®

For peripheral external cooling

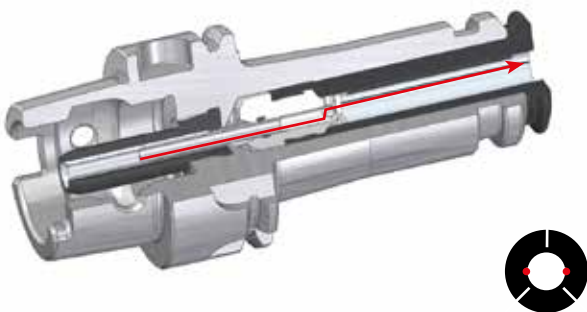

For internal cooling

